



User Manual

MPPT100 Solar Regulator

Description

The MPPT100 Solar Regulator is used to Regulate the Charge of **Lithium-Ion** or Lead Acid Batteries, when charged from PV (Photovoltaic) Solar Panels. By doing **Maximum Power Point Tracking**, it ensures that you always get the maximum available power from your PV Panels.

Parallel Operation

Up to 30 MPPTs can be connected in Parallel.

LCD Display & Keypad

The LCD Display and Keypad give you access to real-time values of all parameters. The system can be configured and all settings can be done with the LCD display and keypad.

Remote Monitoring

If the MPPTs is used with at least one **JSM 8kVA 48V Inverter/Charger**, the system can be monitored remotely with the use of a Riot Cloudlink. All data can be stored and displayed on the Riot portal.

Programable Relay (Optional)

A **30Amp** AC Relay can be added, which can be programmed to switch on and off at Voltage Levels.

1 Specifications

2 Protection

3 Mounting

4 Connections

4.1 Battery Cables, 4.2 PV(Solar) Cables, 4.3 Ground Wire, 4.4 Communication,
4.5 Battery Temperature, 4.6 Programable Relay Coil

5 Switching On

6 LCD Display and Keypad

6.1 Viewable Parameters, 6.2 System Setup, 6.3 Settable Parameters

7 Equalizing Batteries

8 Data Logging

9 Programable Relay

1 Specifications

Solar Input Voltage Range	:	30 - 200 Vdc
MPPT Voltage Range	:	30 – 160 Vdc
Battery Output Voltage	:	24V, 36V or 48V (Self-detect)
Output Current	:	100A max (settable)
Charging scheme	:	Bulk/Absorb/Float & Equalize for Lead Acid Batteries
Efficiency	:	>95%
Cooling	:	Fan-Cooled (Switch on if Heat-sink is above 50°C)
Dimensions (h x w x d)	:	380mm x 250mm x 150mm
Weight	:	7.2kg

2 Protection

Over Current Protection	:	Electronic as well as Battery & PV Circuit Breakers
Over Voltage Protection	:	200 V
Over Temperature Protection	:	Limit Current above 70°C on Heat-sink, Switch of @ 75°C

3 Mounting

Use the supplied bracket and mount it level onto the wall with 6mm nail-ins, with the slots facing upwards.



Hook the MPPT onto the bracket. Tighten the nuts onto the bracket.

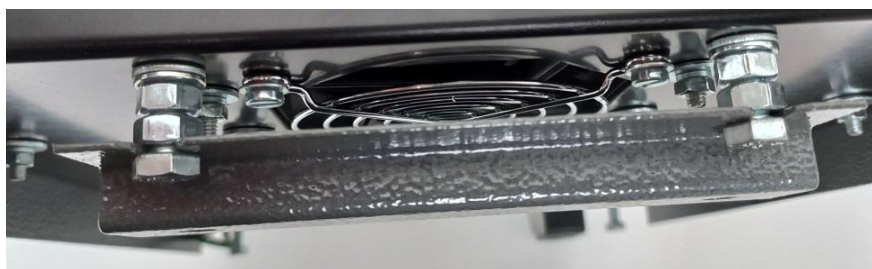

Fix the bottom bracket to the wall with a 6mm nail-in.



4 Connections

Make sure that both Circuit Breakers are switched off before the Batteries and Solar Panels are connected.

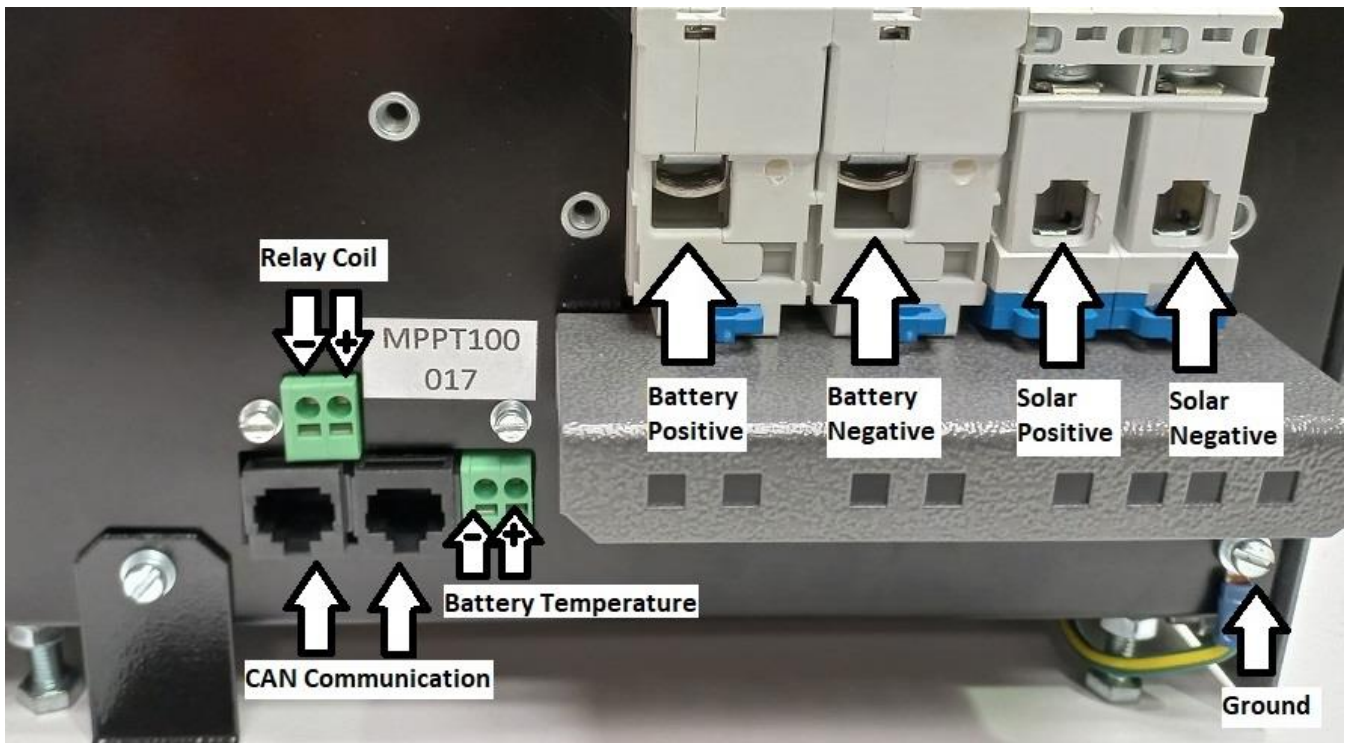

4.1 Battery Cables

Do not reverse the polarity of the Battery connections. The Battery cables should be at least 25 mm² if operated at 100Amp. The Battery Positive Cable goes into the left output on the Battery Circuit Breaker. The Battery Negative Cable goes into the right output of the Battery Circuit Breaker.

4.2 PV(Solar) Cables

Do not reverse the polarity of the PV connections. The PV cables should be at least 10 mm² if operated at 100Amp (Battery Current). For optimal efficiency the MPPT voltage of the Solar Panels must be more or less double the nominal battery voltage. **The Solar input current must not exceed 60Amp.**

It is always better to connect the solar panels to get the highest possible voltage, not exceeding 200V Open Circuit Voltage. The higher the Voltage, the lower the number of Strings and the less wire you use.

4.6 Ground Wire

The casing of the MPPT100 must be Grounded (Earthed). Use the terminal indicated in the picture. Leave the existing wire also connected.

4.4 Communication

If more than one MPPT100 is used, CAN communication can be used to synchronize the MPPTs. It can also be connected to the **CAN2** port on the Master Inverter on a JSM 8kVA Inverter/Charger system. The Master Inverter will then control the Charging Algorithm.

Cat5 4pair network cable must be used. Only PIN1(CAN High) and PIN2(CAN Low) is used and must be a twisted pair. The rest of the wires are not used. The cable must be one to one and standard Network cables can also be used.

The connections are Daisy Chained and must be terminated at the two ends with 120 ohms (termination supplied with MPPT). The Connection on the Inverter CAN2 is already terminated.

4.5 Battery Temperature (Optional)

On Lead Acid batteries, it can prolong the life of the batteries if Temperature Compensation is used in the Charging Algorithm. A Temperature Sensor can be used to measure the temperature of the battery. It is normally connected on the negative terminal of the battery. Insert the **Red(+)** wire in the right hand side terminal and the **Blue(-)** wire in the Left hand side terminal as indicated in the picture above. The pinout is also shown on the front label.

4.6 Programable Relay Coil

See section 9.

5 Switching On

Before the Circuit Breakers are switched on, make sure of the polarity of the Battery and Solar Cables. Make sure all the connections are tightened. Switch on the Battery Circuit Breaker.

One of the following screens will be displayed. If the first screen is displayed, it means that the regulator is connected to a different battery than before. The regulator measures the battery voltage at start-up and automatically determine the Battery Voltage (24V, 36V or 48V). For safety this needs to be confirmed by the user. If you are happy with the selection of the Battery Voltage, just press **Up**. Else press **Enter**. The Voltage will flash. Press **Up** or **Down** to change the Voltage. Press **Enter**. Then press **Up** to confirm your decision. It will then ask you to press **Enter** to save the settings. Press **Enter** and the second screen will appear.

				4	8	V	S	y	s	t	e	m	?			
				U	p		t	o		C	o	n	f	i	r	m

B	A	T	:	4	8	.	2	V					0	0	0	A
S	O	L	:	0	0	0	V						L	O	W	

If the second screen is displayed with power-up, it means that the System Voltage did not change since the last time the regulator was started-up. Switch on the Solar Circuit Breaker. The Solar Voltage will be displayed. After 5 seconds the Regulator will start charging the battery, if there is enough power available from the sun. While the regulator is charging the batteries, it will keep changing the Solar Voltage to determine what the MPP (Maximum Power Point) Voltage of the panels is, for optimum performance.

6 LCD Display and Keypad

The LCD Display and Keypad is used to view and set certain parameters.

6.1 Viewable Parameters

There are 8 Viewable Parameters that are displayed over 4 different screens. The 4 screens are shown below. Use the UP and DOWN buttons to scroll through the screens.

B	A	T	:	4	8	.	2	V					8	5	A	
S	O	L	:	1	2	3	V						B	u	l	k

On the above screen the **Battery Voltage(1)**, **Battery Current(2)**, **Solar Voltage(3)** and **Charging State(4)** are displayed. The different Charging States are **Bulk**, **Absorb**, **Equalize**, **Float** and **Low**. If **Low** is displayed it means that the available power for the sun is too low to charge the batteries, or the batteries are full. While Solar Voltage greater than the Battery Voltage is present the regulator will start up every 5 minutes to see if there is enough power to charge the batteries.

I	n	t	o		B	A	T		P	=	4	0	9	7	W
T	o	d	a	y					1	2	.	4	k	W	h

The above screen display the instantaneous **Power into the Battery(5)** and the **Energy (kWh) into the Battery for Today(6)**. This counter is cleared each morning when the sun rise.

H	e	a	t	s	n	k		T	m	p	:	3	5	°	C
B	a	t	t	e	r	y		T	m	p	:	2	5	°	C

The above screen display the **Heatsink Temperature(7)** and **Battery Temperature(8)** (see 4.5). If the heatsink temperature rise above 50°C, or the Battery Current is above 60Amp, the cooling fan will switch on, to cool down the heatsink and the inside of the regulator.

0	1	d	a	y	s		←		1	2	.	7	k	W	h
B	A	T	:		4	7	.	1	V	-	5	5	.	1	V

The above screen shows logged data. This is explained below in section **8 Data Logging**.

6.2 System Setup (password 123)

The System Setup is necessary if you use more than one MPPT100 with communication between them. Press the **Menu** button. The following Screen will appear. Press **Enter**. The value will start to flash. Use the **Up** and **Down** buttons (can be held in for quick counting) to set it to **123**. Press **Enter**.

P	a	s	s	w	o	r	d		t	o		S	e	t	-
U	p		S	y	s	t	e	m				0	0	0	

You need to set the **Direction & Number** of each MPPT. Each MPPT need to have a unique identity. You can set it as North 1 to 10, West 1 to 10 or East 1 to 10.

You need to set each MPPT as a **Master or Slave**. You need to have **one Master**. The rest must all be set as slaves. With the communication cables connected, you only need to set the Parameters on the **Master MPPT** or the **Master Inverter**. All the other devices will ask you to press UP to save the new Parameters, every time it see that changes has been made to the Parameters.

6.3 Settable Parameters (password 234)

To access these parameters, you need to press the **Menu** button. The **Setup System** Screen will appear. Press **Up**. The following Screen will appear. Press **Enter**. The value will start to flash. Use the **Up** and **Down** buttons (can be held in for quick counting) to set it to **234**. Press ENTER.

P	a	s	s	w	o	r	d		t	o		S	e	t	
P	a	r	a	m	e	t	e	r	s				0	0	0

If you want to change a parameter, press **Enter**. The value will flash. Use **Up** and **Down** to change the value and then press **Enter**. Press **Up** to go to the next parameter, or **Down** to go back to the previous parameter. You need to go to the end of the list to **SAVE** any changes. The screens will appear in the following sequence. (Default setting in bold).

1. **Float Voltage** (12V – 15V/ 12V battery) – **13.5 V / 12V battery**
2. **Absorb Voltage** (12V – 15V / 12V battery) – **14V / 12V battery**
3. **Absorb Time** (0 – 600 min) – **60 min**
4. **Equalize Voltage** (12V – 16V / 12V battery) – **14V / 12V battery**
5. **Equalize Time** (0 – 600 min) – **60 min**
6. **Maximum Charge Current** (10A – 100A) – **100A**
7. **Days between Equalize** (0 – 90days) – **OFF**
8. **Aux Relay Mode** (Voltage Levels, In Float or Disabled) - **Disabled**
(If Voltage Levels is selected)
 - 8.1 **Aux Relay ON Voltage** (12V – 16V / 12V battery) – **14 V**
 - 8.2 **Aux Relay OFF Voltage** (12V – 16V /12V battery) – **13.5V**
9. **System Voltage**

7 Equalizing Batteries

Most Lead Acid batteries need to be equalized from time to time. The Regulator can be set to do an automatic equalize cycle every few days or the user can do an equalize cycle manually. To do a manual equalize press the **Menu** button. The **Setup System** Screen will appear. Press **Up** till the following Screen will appear. Press **Enter**. The “N” for No will start to Flash. Press **Up** to change it to a “Y” for Yes. When you press **Enter**, the Equalize Cycle will start. Press **Menu** to go back to the Viewable parameters.

S	t	a	r	t	E	q	u	a	l	i	z	e
C	y	c	l	e	N							

For **Automatic Equalize**, set the parameter “*Days between Equalize*” to the number of days you want between each Equalize Cycle.

8 Data Logging

Data is logged for up to 99 days back. “01days” means yesterday’s data, “02days” is the data for 2 days ago and so on. Data is updated in the morning when with sunrise.

The minimum and maximum battery voltage is displayed, as well as the kWh’s generated for that specific day.

See the last part of Section **6.1 Viewable Parameters**, for how to access this data.

If the Reset Button is pushed or the Battery Circuit Breaker is switched off, all these saved values will be cleared.

9 Programmable Relay

An **optional** 30Amp Programmable Relay can be mounted onto the MPPT100. It can be used to switch on any non-essential 230V AC loads, under certain batteries conditions. See number **8** in section **6.3 Settable Parameters**. The relay can be switched on if the Batteries State reaches Float (after Absorption is finished), or at settable Voltage levels.

1. If “**Aux Relay Mode**” is set to “**On in Float**”, the Relay will switch on if the Batteries State reaches **Float**. It will switch off when the Battery Voltage drops 1V below the Float Voltage.
2. If “**Aux Relay Mode**” is set to “**Voltage Levels**” Relay will switch on if the Battery Voltage is rise above “**Aux Relay ON Voltage**” for more than 1 minute. The Relay will switch off if the Battery Voltage drops below “**Aux Relay OFF Voltage**” for more than 1 minute.

“The End”

Enjoy your High Quality, South African Developed and Manufactured product.